



Boca Systems

LEMUR-CS PRINTER

Operator's Manual



Table of Contents

Page

FCC Notice & Warranty Information	2
1.0 Unpacking the printer Introduction	3
2.0 Introduction for Lemur-CS	4
3.0 Important Safety Information	5
4.0 Installation	6
5.0 Media Load Procedure	7
6.0 Standard Interface Pinouts	9
7.0 Thermal Paper – Theory & Specifications	10
8.0 Maintenance	11
8.1 Thermal Print Head	12
8.2 Optical Sensors	13
8.3 Platen	14
8.4 Cutter Assembly	14
9.0 Troubleshooting Guide	15
10.0 Spare Parts	17
Appendix A - ETHERNET PARAMETERS	18
Appendix B – MAC DRIVER INSTALLATION GUIDE	20
Appendix C – WINDOWS DRIVER INSTALLATION GUIDE	20
Appendix D – TESTING A LEMUR-CS	21
Appendix E – DOWNLOADING SOFTWARE COMMANDS	22
Appendix F – BLUETOOTH CONNECTION	25
Appendix G – CONFIGURE WI-FI CONNECTION	29
Appendix H- SERVICE PLANS	33
Appendix I – TECHNICAL SUPPORT	33

FCC NOTICE

NOTE: The equipment has been tested and found to comply with the limits for a class A digital device, pursuant to part 15 of the FCC rules. These limits are designed to provide reasonable protection against harmful interference when the equipment is operated in a commercial environment. This equipment generates, uses, and can radiate radio frequency energy and, if not installed and used in accordance with the instruction manual, may cause harmful interference to radio communications. Operation of this equipment in a residential area is likely to cause harmful interference in which case the user will be required to correct the interference at the user's expense.

Operation is subject to the following two conditions:

1. This device may not cause harmful interference, and
2. This device must accept any interference received, including interference that may cause undesired operation.

NOTE: This unit was tested with shielded cables on the peripheral devices. Shielded cables must be used with the unit to ensure compliance.

WARRANTY INFORMATION

All warranty work is to be performed either by BOCA or by an [authorized BOCA service center](#). Shipping charges to the repair center are the customer's responsibility. BOCA will pay for the equipment's return via ground service. Parts damaged by negligence or misuse (bad ticket stock, improper operating conditions, etc.) are excluded from this warranty. (NOTE: The print head is a consumable part and is warranted for ninety days.)

New Equipment - BOCA warrants the equipment manufactured and sold by it to be free from defects in material and workmanship under normal use and service for one year from the date of shipment.

Repairs - A factory repaired printer is warranted for ninety days after being received by the customer. The repair warranty covers only the specific repair work performed and does not cover subsequent failures unrelated to the repaired components.

Parts - Spare parts carry a ninety-day warranty.

Tickets - Tickets are warranted, under proper storage conditions, for a period of three years.

Please go to the link below if you have any reported issues with your new BOCA printer.

<https://www.bocasystems.com/onlinesupportformNEW.html>

Equipment damaged in shipping should be reported immediately both to BOCA and to the shipper.

EXTENDED WARRANTY PLAN - BOCA offers [extended warranty plans](#) for all printer models. These plans cover all parts and labor. All labor is to be performed at the BOCA facility. Equipment damaged by misuse or negligence, including damage to print heads caused by defective ticket stock, is excluded from this extended warranty. The customer, at its option, may request BOCA to ship individual parts to expedite simple repair procedures. In certain cases where the customer is unable to wait for the normal repair cycle, BOCA will ship an exchange printer within one business day after notification by the customer. All freight charges are the responsibility of the customer.

Click here to return to > [Table of Contents](#)

1.0 Unpacking the Printer

The printer is shipped in a ruggedized container. **Please save packing material for future use.** Remove the printer and accessories from the box and inspect for obvious damage. If damage is noticed, please report it immediately to BOCA.

Email: cathy@bocasystems.com Tel: (561) 998-9600 Fax: (561) 998-9609

The following items should be in the box:

- A) Lemur-CS
- B) 24VDC power supply
- C) AC cord
- D) May come with below options (depending on what was ordered):
 - a. Interface cable(s)



Above shows typical packing of printer.

Click here to return to > [Table of Contents](#)

2.0 Introduction Lemur-CS

The Lemur-CS is a direct thermal ticket printer with optional integrated cutting mechanism. This manual will provide the user with general information regarding printer set-up, configuration and troubleshooting. Please read the important safety information section before installation is conducted.

The Lemur-CS is a low-cost point of sale printer designed for use with 1" (25.4mm) to 3.25" (82.5mm) wide thermal roll media with one inch center core. May be configured for use with receipt or media with black timing mark (https://www.bocasystems.com/ticket_specs13.html). Optional configuration for uses with die cut labels without black timing mark.

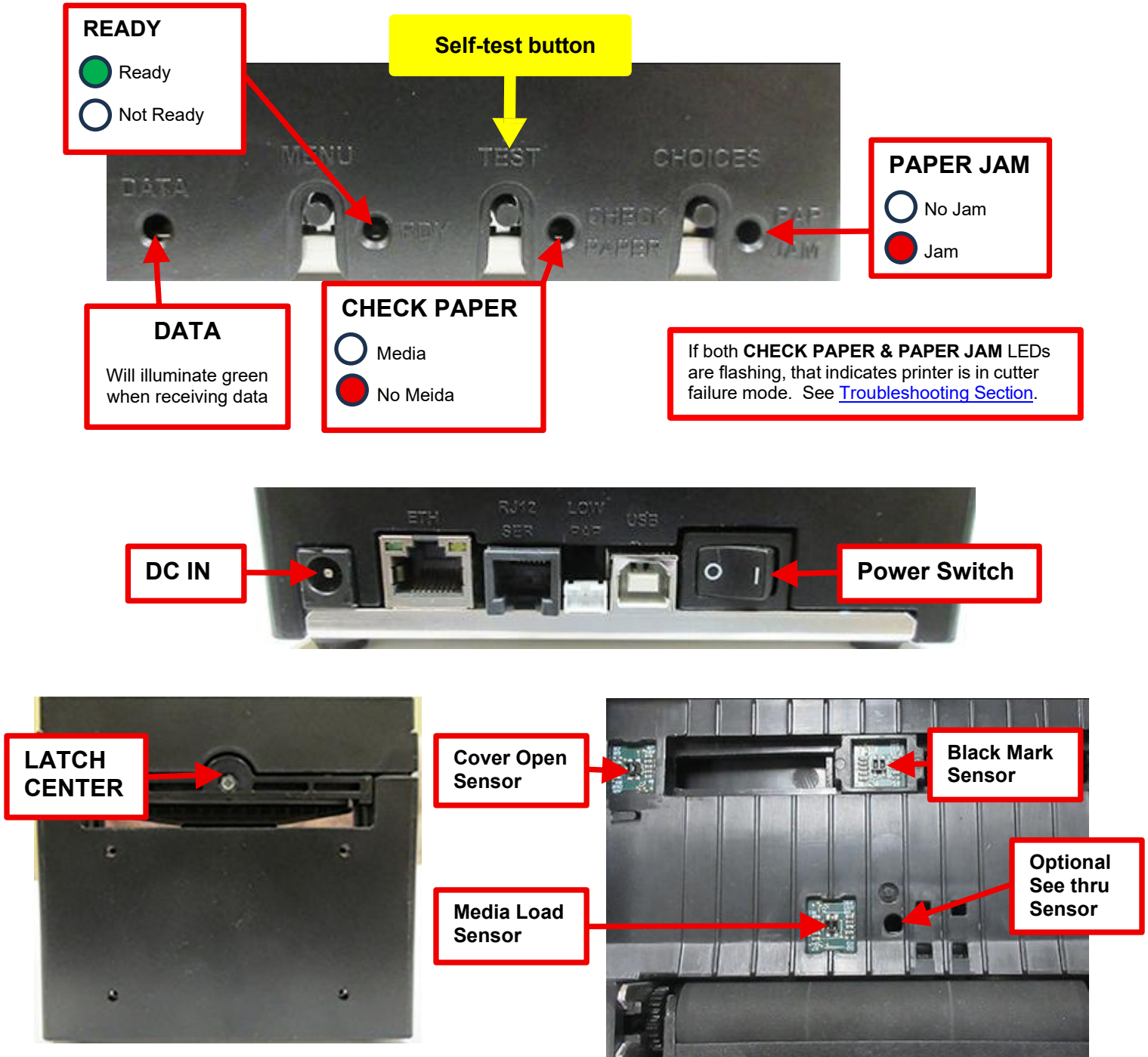

The black mark sensor does have the ability to be adjusted from side to side. See section [8.2 Optical Sensors](#).

Click here to return to > [Table of Contents](#)

3.0 Important Safety Information



WARNING: The appearance of this symbol indicates the proximity of an exposed high voltage area. Please follow all directions carefully for your personal safety. You must read the following safety information carefully before working on the printer.

As a safety precaution, all service to the printer should be done by **qualified persons with power off and the AC cord unplugged from the printer. Following any procedure requiring the removal of covers and/or doors, please verify that they have been properly attached and fastened prior to operating the printer.**

WARNING: "Provide an earthing connection before the mains plug is connected to the mains. And, when disconnecting the earthing connection, be sure to disconnect after pulling out the mains plug from the mains."

WARNING: Power Cord Set: This must be approved for the country where it is used:

U.S.A. and Canada

- The cord set must be UL-approved and CSA certified.
- The minimum specification for the flexible cord is:
 - No. 18 AWG
 - Type SV or SJ
 - 3-conductor
- The cord set must have a rated current capacity of at least 10A.
- The attachment plug must be an earth-grounding type with a NEMA 5-15P (15A, 125V) or NEMA 6-15P (15A, 250V) configuration.

United Kingdom only

- The supply plug must comply with BS1363 (3-pin 13 amp) and be fitted with a 5A fuse which complies with BS1362.
- The mains cord must be <HAR> or <BASEC> marked and be of type H03VVF3GO.75 (minimum).

Europe only:

- The supply plug must comply with CEE 7/7 ("SCHUKO").
- The mains cord must be <HAR> or <BASEC> marked and be of type H03VVF3GO.75 (minimum).

Denmark: The supply plug must comply with section 107-2-D1, standard DK2-1a or DK2-5a.

Switzerland: The supply plug must comply with SEV/ASE 1011.

China: The product label is on the bottom of the equipment. It is also located near where the AC cord plugs into the printer.

产品的标识在设备的底部

WARNING: The appliance coupler (the connector to the unit and not the wall plug) must have a configuration for mating with an EN60320/IEC320 appliance inlet.

WARNING: The socket outlet must be near to the unit and easily accessible.

WARNING: France and Peru only:

This unit cannot be powered from IT \uparrow supplies. If your supplies are of IT type, this unit must be powered by 230V (2P+T) via an isolation transformer ratio 1:1, with the secondary connection point labelled Neutral, connected directly to earth (ground).

WARNING: RJ-45 Ports. These are shielded RJ-45 data sockets. They cannot be used as standard traditional telephone sockets, or to connect the unit to a traditional PBX or public telephone network. Only connect RJ-45 data connectors. Either shielded or unshielded data cables with shielded or unshielded jacks can be connected to these data sockets.

Click here to return to > [Table of Contents](#)

4.0 Installation

The Lemur-Q is designed to be mounted on a flat level surface.

Prior to site preparation and installation, the printer should be powered up and run in the self-test mode.

1. Place the printer on a flat level surface.
2. Plug the round DC connector of the 24VDC power supply into the printer's DC IN.
3. Plug the AC cord into the 24VDC power pack.
4. Load media into the printer. See section [5.0 Media Load Procedure](#).
5. Power the printer ON.
6. You will hear the cutter cycle (if equipped with auto cutter). Depending on how the printer is configured it may feed out on piece of blank media.
7. The green READY LED will be illuminated, press the center TEST button on the control panel to print a test ticket.

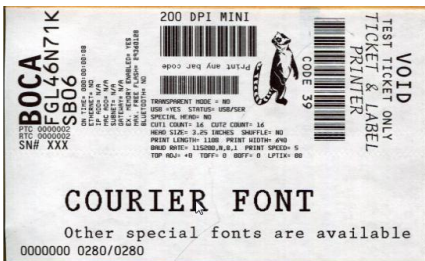

- i. Your printout may vary depending on printer configuration and ticket stock used
8. Interface connection:
 - a. **Bluetooth** (Optional) – See [Appendix F](#).
 - b. **Ethernet** (Optional Activation) – See [Appendix A](#).
 - c. **USB** – Check with your software provider to see if their software requires the use of the BOCA printer driver (MAC or Windows)? If so, then see [Appendix B](#) for MAC and [Appendix C](#) for WINDOWS.
 - d. **Wi-Fi** (Optional) – See [Appendix G](#).
9. Verify that the printer properly works with your system by issuing a ticket through your computer system. You may also use our customer-based program to test the printer independently of your ticketing system (see [Appendix D](#)).
10. When Lemur-CS leaves the factory, it may be configured in two ways depending on how it was ordered from the factory:
 - a. For use with media that has a black timing mark (**default**).
 - b. For use with media that does not have a black timing mark. Receipt Mode.
 - c. For use with die cut labels without black timing mark.

See [Appendix E – DOWNLOADING SOFTWARE COMMANDS](#) to download the appropriate software command.

- i. **<pmd>** this will configure the printer for use with ticket stock with a black timing mark.
- ii. **<pmr>** this will configure the printer for use with receipt stock without a black timing mark.

5.0 Media Load Procedure

1. Open the cover of the printer. This is done by pressing in on the center of the latch.



2. Open cover.
3. Slide apart the roll holder holders.

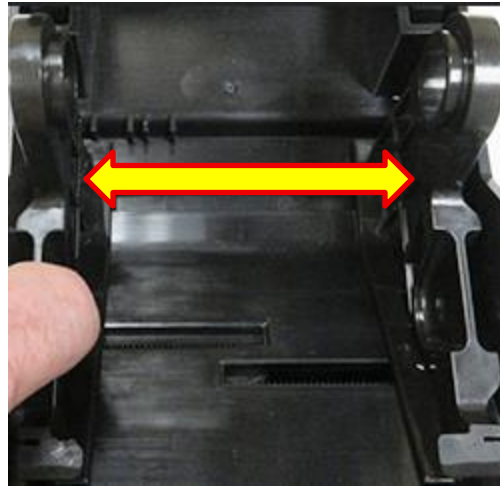
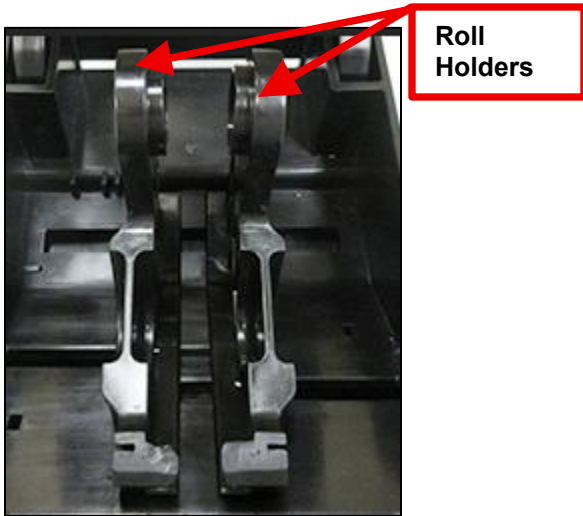

4. Align the hub of the roll holders with the center core of the media and allow roller holder to close. Securing the roll in place and able to rotate freely.

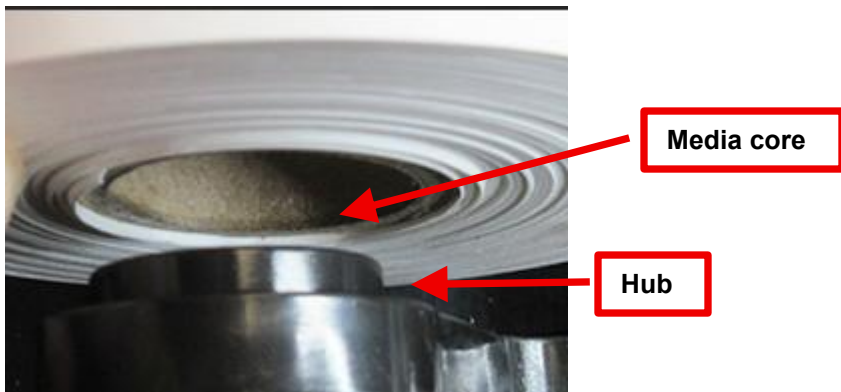

Below shows various media rolls properly installed.



5. Feed media under the guide tabs.

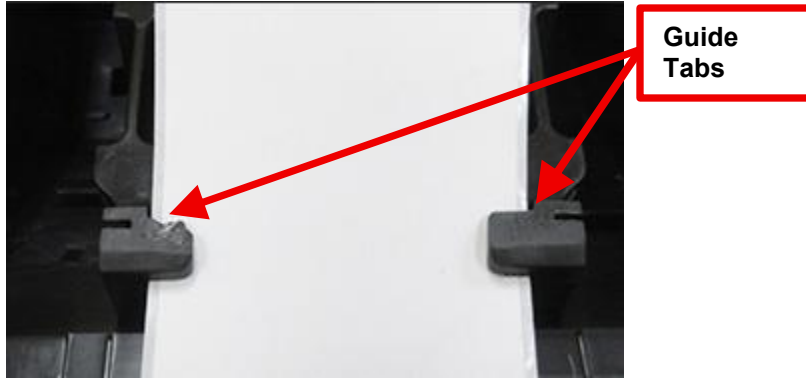

6. Pull the media forward until it covers the platen (robber roller). As shown below.



7. Gently close the cover of the printer and make sure it is locked closed.

6.0 Standard Interface Pinouts

RJ12 Serial Connection

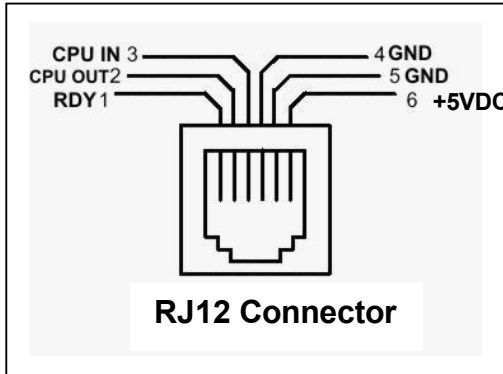

TYPICAL DB9 to RJ12 PIN CONNECTIONS

9 pin host	BOCA RJ12	
2	2	Transmit
3	3	Receive
5	4	GND
6	1	RDY
8	6	CTS

USB USB 2.0 compliant devices.

LOW PAPER PORT Not used.

BLUETOOTH (Optional) Allows connection via Bluetooth interface.

WI-FI (Optional) is compatible with 802.11b/g/n Wi-Fi router and supports security settings WEP/WPA/WPA-2. Printers built after July 2020 (s/n 452607 and higher) can support 802.11b/g/n Wi-Fi router. On dual-band router our printer needs be configured for the 2.4GHz band.

ETHERNET (Optional) is a standard RJ45 Ethernet cable connection. Printer will physically have this connector, but it will be disabled if the printer was not originally ordered with the Ethernet feature. We offer an Ethernet activation license code to activate this port if it was originally disabled.

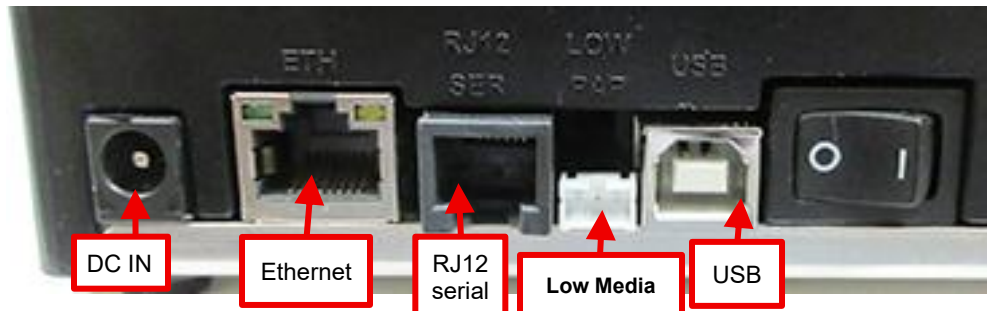

Click here to return to > [Table of Contents](#)

7.0 Thermal Paper - Theory & Specification

Refer to the BOCA Systems website at www.bocasystems.com, [THERMAL TICKETS](#) section for the most current [paper specifications](#).

The print head's life expectancy is composed of both a mechanical and an electrical component. Both factors are strongly influenced by the quality of the thermal paper used.

MECHANICAL

The print head has a theoretical rating of 60 kilometers. This number is based upon the assumption that the head will be used with good quality, top coated thermal paper. Uncoated and poorly top coated thermal papers are abrasive to the print head and have been found to wear through the head after less than one kilometer.

Other factors which may contribute to premature mechanical wear are the use of non-thermal inks and stray metallic particles stuck in ticket perforations. Certain ink colors such as opaque white (which contains titanium dioxide) are also highly abrasive.

Unfortunately, there are no available devices for quantitatively measuring the abrasiveness of a given ticket. Fortunately, we have developed a slightly subjective, but effective method of weeding out overly abrasive ticket stock.

ELECTRICAL

Each heat element, dot, on the print head has a theoretical life expectancy of 100 million activations. This assumes that each activation will cause the dot temperature to approach the dot's maximum recommended temperature. Running at lower temperatures will increase the theoretical life expectancy, while slight temperature increases will seriously (exponentially) degrade the head life.

The thermal paper can affect electrical head life in two ways. Insensitive, slow papers will typically encourage the user to increase the voltage to darken the printed image. This will directly increase the head temperature resulting in reduced head life. Additionally, the higher temperatures will frequently cause the ink to peel off the ticket and deposit onto the print head. The ink debris will disrupt the normal transfer of heat from the head to the paper. This further increases the head temperature above the desired level. The use of non-thermal inks and/or non-top coated paper also will cause the ink to release and deposit on the print head.

SPECIFICATION

Based upon the above technical information, BOCA has always tried to encourage our customers to use proper thermal papers to maximize the life of their print heads. BOCA provides an extensive series of papers which meet the above criteria for low abrasion and high sensitivity. We have also tested and approved a few Ricoh thermal papers which meet our criteria. While we have not had the opportunity to test other manufacturers' thermal papers, we feel confident that other papers manufactured with the above goals in mind should be acceptable for use in our printers. The following list of papers has been approved by BOCA.

200 dpi usage

Lemur-X T4, T5, BS7, SKI7 & T7

Click here to return to > [Table of Contents](#)

8.0 Maintenance

Your ticket printer is solidly constructed and requires minimal care to provide maximum service.



WARNING: The appearance of this symbol indicates the proximity of an exposed high voltage area. Please follow all directions carefully for your personal safety. You must read the following safety information carefully before working on the printer.

This section provides an overview of printer maintenance.

For discussion purposes, the printer consists of three major modules or assemblies:

- Platen, sensors (optos) and print head assembly
- Cutter

As a safety precaution, all service to the printer should be done by [qualified persons](#) with power off and the AC cord unplugged from the printer. Following any procedure requiring the removal of covers and/or doors, please verify that they have been properly attached and fastened prior to operating the printer.

Routine Maintenance – Routine maintenance should normally be done a minimum once a year. Printer may require increased maintenance due to usage and environmental conditions.

See following link:

https://www.bocasystems.com/documents/RoutineMaintenanceLemur_CS.pdf

8.1 Thermal Print Head

The print head should be cleaned periodically to prevent debris from building up on the print element. The required cleaning interval varies greatly depending on the quality of the ticket stock and the amount of dust entering the print area. Excessive dirt buildup on the print head will result in reduced quality. Continuing to run the print head in a dirty condition will reduce its life expectancy, as it is unable to diffuse heat properly.

The thermal print head can easily be accessed for cleaning or replacement, as follows:

1. **Power off the printer.**
2. Open the cover of the printer. This is done by pressing in on the center of the latch.



3. Open cover.
4. Clean the thermal print head surface with isopropyl alcohol.

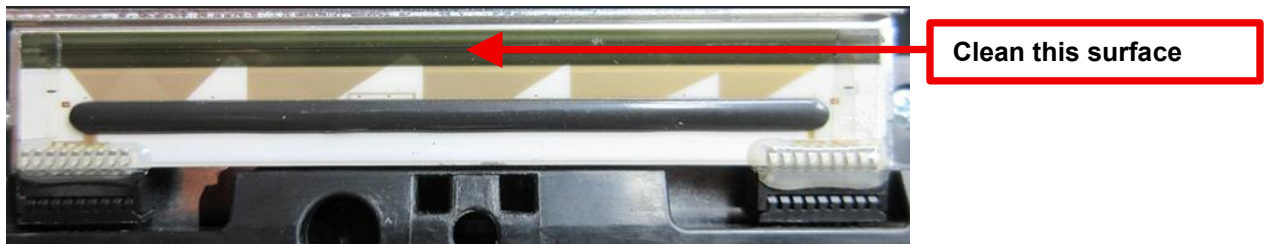

5. While the cover is open, recommend cleaning the [sensors](#), [platen](#) and [cutter area](#) (is so equipped).
6. Gently close the cover of the printer and make sure it is locked closed.

Click here to return to > [Table of Contents](#)

8.2 Optical Sensors

There are multiple optical sensors (opto) which are responsible for detecting the media and if the cover is open.

Once a year the sensors should be blown off with air. This interval will vary depending upon the environment and the quality of the ticket stock. You may get access to the sensors by opening the print head assembly.

1. **Power off the printer.**
2. Open the cover of the printer. This is done by pressing in on the center of the latch.



3. Open cover.
4. Blow off the sensor with canned air.

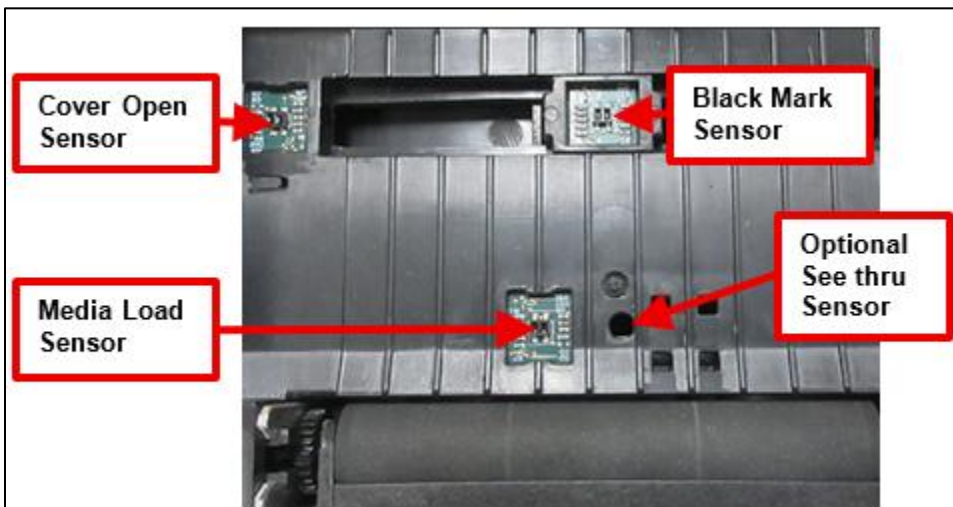

5. While the cover is open, recommend cleaning the [platen](#) and [cutter area](#) (if so equipped).
6. Gently close the cover of the printer and make sure it is locked closed.

The black mark sensor does have the ability to be adjusted from side to side to accommodate media that may not have a center black timing mark.

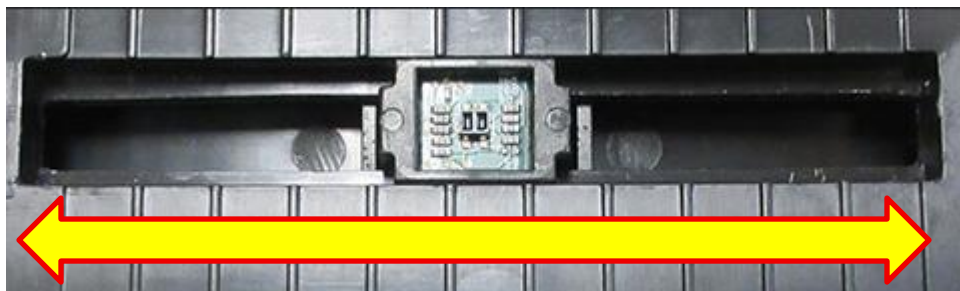

Click here to return to > [Table of Contents](#)

8.3 Platen (Rubber Driver Roller)

The Platen (rubber drive roller) should be cleaned once a year to prevent paper dust from building up on the roller. (NOTE: The platen may require more frequent cleaning in dusty environments or when using inferior ticket stock.)

1. Power off the printer.
2. Open the cover of the printer. This is done by pressing in on the center of the latch.



3. Open cover.
4. Apply a small amount of Isopropyl alcohol onto a paper towel to clean the rubber roller.
5. Clean only the part of the rubber roller where the media makes contact. In the below example only clean the area where the wristband contacts the platen (yellow highlighted area).

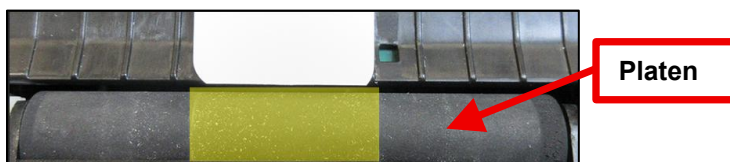

6. Rotate the rubber roller clockwise a little and repeat step 4; continue in the same manner for one full revolution of the rubber roller.
7. While the cover is open, recommend cleaning the [cutter area](#) (if so equipped).
8. Gently close the cover of the printer and make sure it is locked closed.

8.4 Cutter Assembly

The cutter area should be blown out with air periodically to prevent debris from building up inside the cutter area and clean off the cutter knife sensor. The required cleaning interval varies greatly depending on the quality of the media and the amount of paper dust entering the cutter area. This is done while the print head is open. Blow out the area highlighted in yellow.

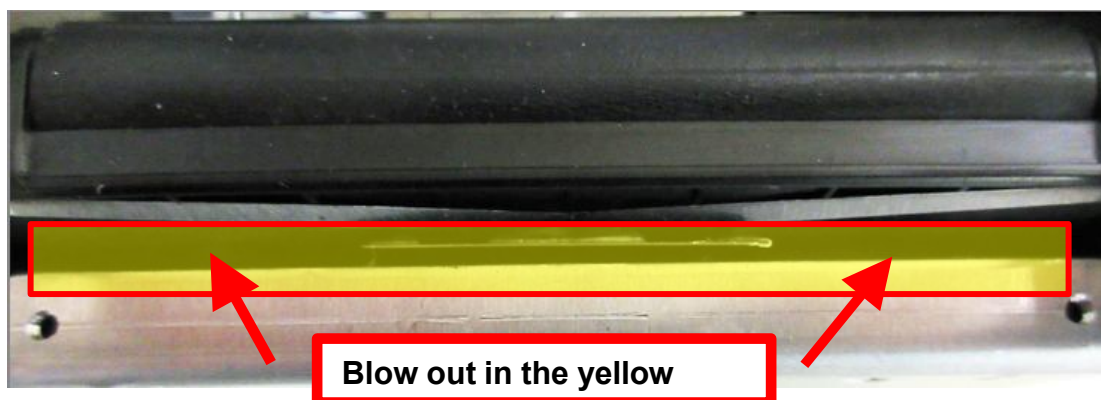

Click here to return to > [Table of Contents](#)

9.0 Troubleshooting Guide

This is a simplified troubleshooting guide listing some of the typical problems. It is not intended to provide technical details or repair methods but can serve as a guide to fault isolation in the field. **As a safety precaution, all service to the printer should be done by qualified persons with power off and the AC cord unplugged from the printer. Following any procedure requiring the removal of covers and/or doors, please verify that they have been properly attached and fastened prior to operating the printer.** If you need additional help, please visit the link below www.bocasystems.com/onlinesupportform.html

1. NO OPERATION, LED'S DON'T LIGHT UP UPON POWER UP
 - a. Unplug the AC cord from the power source and wait 30 seconds then plug it back in.
 - b. Check the power cord for proper installation at both ends.
 - c. Check that there is power at the AC outlet.
 - d. Replace the 24 VDC power supply.
 - e. Contact your system provider or [BOCA](#) for further assistance.

2. POWER IS ON BUT NO OPERATION
 - a. Make sure the media is loaded properly into the printer. Consult section [5.0 Media Load Procedure](#).
 - b. Make sure the cover is fully locked closed.
 - c. Perform routine maintenance on the printer. Consult section [8.0 Maintenance](#)
 - d. If cutter knife does not go up and down after power up, See # 6.
 - e. Default the printer settings. With the printer powered off, hold down the center TEST button and then power up the printer. Keep the TEST button held down for 10 seconds and release (printer will reset).
 - f. Contact your system provider or [BOCA](#) for further assistance.

3. POWER ON BUT NO OPERATION (2 RED LED ARE FLASHING)
 - a. Make sure there is no media jammed in the cutter area.
 - b. Perform routine maintenance on the printer. Consult section [8.0 Maintenance](#).
 - c. Default the printer settings. With the printer powered off, hold down the center TEST button and then power up the printer. Keep the TEST button held down for 10 seconds and release (printer will reset).
 - d. Contact your system provider or [BOCA](#) for further assistance.

4. POWER IS ON BUT MEDIA WILL NOT FEED
 - a. See # 2
 - b. Contact your system provider or [BOCA](#) for further assistance.

5. ERRATIC CUT POSITION
 - a. Make sure the media is loaded properly into the printer. Consult section [5.0 Media Load Procedure](#).
 - b. Clean off the opto sensors. Consult [8.2 Optical Sensors](#) section.
 - c. Check that the platen is clean. Consult "[8.3 Platen \(Rubber Driver Roller\)](#)" section.
 - d. Contact your system provider or [BOCA](#) for further assistance.

6. ERRATIC PRINT POSITION
 - a. See # 4

7. POOR PRINT OUT (light print out)
 - a. Try a different roll of media.
 - b. Make sure the cover is fully locked closed.
 - c. Clean print head. Consult "[Thermal Print Head](#)" section.
 - d. Contact your system provider or [BOCA](#) for further assistance.

8. POOR PRINT OUT (white voids in print out)
 - a. Try a different roll of media.
 - b. Clean print head. Consult "[Thermal Print Head](#)" section.
 - c. Contact your system provider or [BOCA](#) for further assistance.

9. NO PRINTOUT
 - a. Try a different roll of media.
 - b. Check head cable for electrical connection at both sides of print head.
 - c. Contact your system provider or [BOCA](#) for further assistance.

10. PRINTER SKIPS WHILE PRINTING
 - a. Try a different roll of media.
 - b. Clean off SQ optical sensors (see [8.2 Optical Sensors](#)) with air.
 - c. Check that the platen is clean. Consult "[8.3 Platen \(Rubber Driver Roller\)](#)" section.
 - d. Contact your system provider or [BOCA](#) for further assistance.

11. PRINTER SKIPS WHILE PRINTING AND DIES
 - a. See # 10.

12. ETHERNET WILL NOT CONNECT
 - a. When the Ethernet cable is connected to the printer the DATA LED should start flashing. If it does not:
 - Check to make sure the Ethernet setting is not set to NO. The self-test ticket printout shows the status.
 - Check to make sure the Ethernet connect to the cable is good.
 - b. Your Network IP server may not support the use of a DHCP protocol and require the Ethernet to be set to a static IP address. Ethernet Interface Addendum of the [FGL programing guide](#) reviews how to do this.

13. WI-FI WILL NOT CONNECT OR INTERMITTENT CONNECTION
 - a. Make sure you are connecting to Wi-Fi router that supports 802.11b/g/n devices.
 - b. If using a 802.11 N device, make sure 2.4GHz channel is being used.
 - b. On initial setup, have the printer as close as possible to the Wi-Fi router.
 - c. Check to make sure you have the correct SSID and security values for the Wi-Fi router you are trying to connect to. Please note these values are case sensitive.
 - d. If you have multiple routers change the channel setting to 1, 6 or 11. Multiple routers using the same channel will cause connection and drop single issues.

Click here to return to > [Table of Contents](#)

10.0 Spare Parts List

Will be populated in the future.

Click here to return to > [Table of Contents](#)

APPENDIX A –ETHERNET PARAMETERS

Each Boca Ethernet Printer has a unique MAC address based in part on the printer's serial number. All Boca printers are factory configured in DHCP enabled mode. (Exceptions can be made by special request.) If the printer is unable to get a dynamic IP address from the customer's network in the allotted time (about four minutes). You can select a different fixed IP address via a Web Browser (see below).

ETHERNET – Quick Installation Guide

1. Connected to the printer's IP via a web browser. The printer and web browser need to be on the same network.

When a printer is first powered on, it will try to obtain an IP address from the Network IP servers. After the printer has been left on for 4 minutes, press the center TEST button to print out a self-test ticket. An IP address will be printed on this ticket. If the printer did not get an IP address from the IP server, then it will default to using:

- For "R" version firmware 169.###.###.###

Type the IP address found on the self-test ticket in a web browser. For example, if the printer came up with its default IP 169.254.010.052 they you would type 169.254.10.52 in the browser.

2. You will see the below. Username = boca & Password = printer. Your IP address will be different from what is shown below.

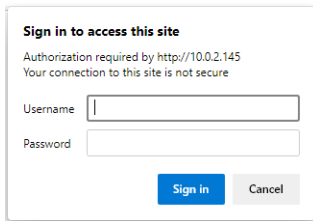

The image shows a standard web browser security warning dialog box. The title is "Sign in to access this site". Below the title, it says "Authorization required by http://10.0.2.145" and "Your connection to this site is not secure". There are two input fields: "Username" and "Password". At the bottom, there are two buttons: "Sign in" (highlighted in blue) and "Cancel".

The menu will come up, click on Submit button to go to the configuration page if you do not want to password protect.

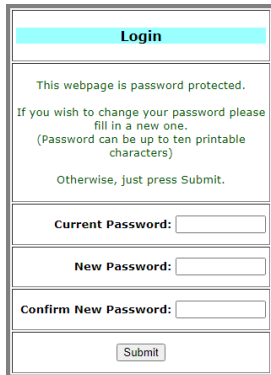

The image shows a web browser's password protection menu. The title is "Login". Below the title, it says "This webpage is password protected." and "If you wish to change your password please fill in a new one. (Password can be up to ten printable characters)". Below this, it says "Otherwise, just press Submit." There are three input fields: "Current Password:", "New Password:", and "Confirm New Password:". At the bottom, there is a "Submit" button.

3. Below shows the configuration page

Boca Systems' Printer Configuration Page

Firmware :	HP46N166 / COM46N166 / SH00
Serial number :	488827
On Time :	000-00:03:27 d/h/m/s
MAC ID :	00.0D.71.07.75.7B

FACTORY MENU : items with an * should not be changed or selected without first consulting Boca Systems.

BAUD RATE=	9600.N.8.1	MINI/MICRO=	MINI	PRINT SPEED=	3	DIAGNOSTIC MODE=	NO
TICKET TYPE=	SPECIAL TICKET	STATUS ENABLED=	USB/SER	TRANSPARENT MODE=	NO	PAPER MODE=	NO
*HEAD DPI=	300	SPECIAL HEAD=	NO	PATH TYPE=	PATH1	BUFFER MODE=	MULTIPLE MODE
CLEAR DOWNLOAD=	NO	DEFAULT SETTINGS=	YES	CUT1 COUNT=	16 (1-200)	CUT2 COUNT=	16 (1-200)
*2-SIDED PRINTER=	NO	PARK TICKET=	NO	TICKET MODE=	MULTIPLE	PRINT MODE=	THERMAL
PRINT INTENSITY=	NORMAL	SKI MODE=	NO	FLASH ACK MODE=	NO	SOFTWARE BUSY=	NO
BI-DIRECTIONAL=	NO	USB=	YES	ACKNOWLEDGE=	NORMAL	ORIENTATION=	NORMAL
FGL COMMANDS=	YES	*HIGH SPEED MODE=	NO	*SHUFFLE MODE=	NO	*CUTTER TYPE=	BOCA
*CUTTER SPEED=	NORMAL	RFID=	NO				
ETHERNET=	DHCP/SUBGATE	IP ADDRESS=	010.000.002.031 (Enter 12 digits)	SUBNET MASK=	255.255.0.0	DEFAULT GATEWAY=	010.000.002.002 (Enter 12 digits)
SPEED/DUPLEX=	AUTO-NEGOTIATE	USB DEVICE TYPE=	PRINTER	BLUETOOTH=	NO	AUTO CASH DRAWER=	NO
MAGNETICS=	NO						

(Press Save button to store)

Configure SNMP

4. If you are going to set a static IP address, then you will need to change the ETHERNET setting to YES. Set IP address, Subnet Mask and Default Gateway to the values you want.
5. If you experience any problems, please refer to the Ethernet section of our [FGL Programming Guide](#).

Click here to return to > [Table of Contents](#)

APPENDIX B– MAC DRIVER INSTALLATION GUIDE

Do not connect the printer to your computer’s USB port until instructed.

Please contact your software provider to confirm if the use of our driver is required for their ticketing software. We recommend that the print driver is installed by either your system administrator or IT support staff.

Below is a link that provides details on how to install the print driver:

www.bocasystems.com/documents/MAC_Driver_Install_Guide_2019.pdf

If you could not install the BOCA print driver using the above steps, please take a screenshot of the “printers and drivers” dialog and attach it to the support form located at

<https://www.bocasystems.com/onlinesupportformNEW.html>

APPENDIX C – WINDOWS USB DRIVER INSTALLATION GUIDE

Do not connect the printer to your computer’s USB port until instructed.

Please contact your software provider to confirm if the use of our driver is required for their ticketing software. We recommend that the printer driver be installed by either your system administrator or IT support staff.

This driver is intended to be installed on Windows PC platforms X86, AMD64 or IA64. This includes Windows 7, 8.1, 10 and Server 2012 R2.

Below is a link that provides details on how to install the printer driver:

www.bocasystems.com/documents/WindowsDriverInstallGuide.pdf

By default, the page size of the driver is Letter size. If your software application requires the page size to be changed to match the media size being used, then see the below:

- Below link shows how to set the printer driver default sizes.
www.bocasystems.com/documents/boca_print_driver_default_size_win_11.pdf
- If you are using media that does not fall within the driver default sizes, then the below link shows how to create a custom page size.
www.bocasystems.com/documents/boca_print_driver_custom_size_win_11.pdf

If you could not install the BOCA printer driver using the above steps, please take a screenshot of the “printers and drivers” dialog and attach it to the support form located at <https://www.bocasystems.com/onlinesupportformNEW.html>

Click here to return to > [Table of Contents](#)

APPENDIX D – TESTING A LEMUR-CS

Boca Systems Inc. has developed various programs that allow customers to communicate from a host computer or mobile device to the printer. Below are the various configure and test programs we offer:

WINDOWS: (Allow connection via Ethernet/ Wi-Fi, Parallel, Serial, USB-HID interfaces and print driver connection)
<https://www.bocasystems.com/documents/Testing%20a%20BOCA.pdf>

MAC: (Allows Ethernet/Wi-Fi, USB-HID interfaces or print driver connection)
<https://www.bocasystems.com/documents/Testing%20a%20BOCAmac.pdf>

iPad: (Allows Bluetooth and Ethernet/Wi-Fi interfaces connection)
<https://apps.apple.com/us/app/bocaprinter/id951179236>

Click here to return to > [Table of Contents](#)

APPENDIX E – DOWNLOADING SOFTWARE COMMANDS

Menu setting changes may be made by utilizing the software commands listed below. This is best done using configure and test program (see [Appendix C](#)).

If needed, the printer may be defaulted back to its original factory settings as follows. With the printer powered off hold down the TEST button and then power up the printer. Keep the TEST button held down for 10 seconds and release (the printer will reset at this time).

Once the customer program is running and is connected to the printer, click on the “Send Text” button. *For the MAC customer program under the Select Printer Operation choose “Send Text Commands”.*

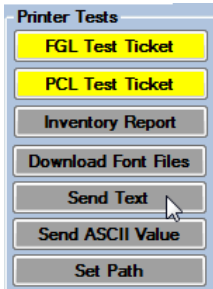

Once the Text Data box comes up you type the text command in the Data input box. Then click on the OK button and the text data will be sent to the printer.

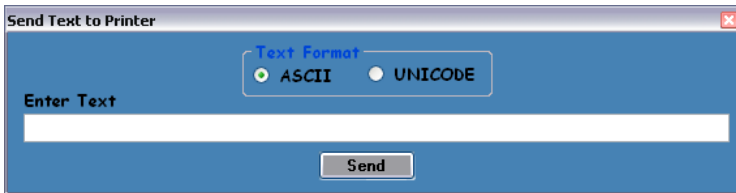

You may click on the HELP button at any time to open the help window.

The following command setting commands are available:

Note: The **kiosk black** mark is at 1.5” for the Lemur-X (www.bocasystems.com/ticket_specs10.html).

If you are using the printer with stock that has a black timing mark, then it will need to be taken out of paper mode.

- **<pmd>** this will configure the printer for use with ticket stock with a black timing mark.
- **<pmr>** this will configure the printer for use with receipt stock without a black timing mark. Full cut mode.
- **<pmr#>** this will configure the printer for use with receipt stock without a black timing mark. It will put the printer in a partial cut mode, so it does not cut all the way through the media. # is the value used for the partial cut setting. Start with a value of 66. You may adjust this value to achieve the desired no cut gap in the media. Decreasing will increase the width of the no cut gap area. **MUST NOT BE USED WITH PRINTER SET FOR BLACK TIMING MARK OR WITH OPTIONAL PRESENTER.**

The printer will reset upon receipt of either above-mentioned software commands.

- **<US>** this command reverses the media behind the platen so it can easily be removed without lifting the printhead. This command should be issued after a ticket has been printed and removed or is idle. The printer will then wait for the ticket to be pulled out completely before trying to reload stock.

Below are Ethernet Mode Commands:

<eth#> the printer will reset after receipt of this command.

This command sets the Ethernet mode for the printer and is permanently stored in flash. This can also be set up using the 'Factory Menu'. The values can range as shown below:

- 0 - NO - Ethernet Interface disabled
- 1 - YES - Ethernet Interface enabled (uses static IP address).
- 2 - Ethernet DIAGNOSTIC Mode - (prints all packets transmitted or received by the printer).
- 3 - Ethernet Diagnostic VALID PACKET Mode - (prints only valid packets transmitted or received by the printer).
- 4 - DHCP ENABLED (automatically attempts to get an IP address from Local Server).
- 5 - DHCP/SUB/GATE (automatically attempts to get an IP address/Subnet Mask/Gateway from Local Server).
- 6 - DHCP/NR* (automatically attempts to get an IP address from Local Server and then register the name with the local NetBIOS name server – usually the WINS Server).
- 7 - DHCP/SUB/GATE/NR* (automatically attempts to get an IP address/Subnet Mask/Gateway from Local Server and then register the name with the local NetBIOS name server – usually the WINS Server).

Click here to return to > [Table of Contents](#)

STATUS COMMAND SETTINGS

The Lemur-X may also be configured for different status command settings.

The printer may only be configured with one of these commands at one given time. Both commands should not be used at the same time. If you are switching from <s90> to <s91> as part of your evaluation you will need to erase the prior status command. This may be done by sending the software command to the printer below. This command will cause the printer to issue out a blank receipt or ticket upon receipt and put the printer back into Normal status mode.

<cs><p>

Solicited Status Mode <s91> (Default) printer will remain online during errors. Printer will issue a black receipt upon receipt of said command. This command only needs to be sent once to take effect. **(default starting January 2024, if not denoted otherwise when ordered)**

When the printer is in an error state, it will only respond to <S92> status requests. Disables most unsolicited status messages, see below table. NOTE: All other data and status requests will be deleted until the printer returns to an error-free condition.

Printer will send the below unsolicited and solicited status messages:

Hex	Dec	Description	Unsolicited	Solicited
06H	6	TICKET ACK – Sent after each receipt or ticket is printed	YES	NO
0FH	15	LOW PAPER – used with optional low paper sensor	YES	YES <S92>
10H	16	OUT OF PAPER – printer runs out of media	NO	YES <S92>
11H	17	X-ON – sent when printer buffer is ready after being full	YES	NO
12H	18	POWER ON – sent when printer is powered on	YES	NO
13H	19	X-OFF – sent when printer buffer is full	YES	NO
18H	24	PAPER JAM – printer is in a media jam error state	NO	YES <S92>
19H	25	ILLEGAL DATA – when printer receives illegal data	NO	YES <S92>
1AH	26	POWERUP PROBLEM – printer has powerup error	NO	YES <S92>
1CH	28	DOWNLOAD ERROR – error downloading font or image	NO	YES <S92>
1DH	29	CUTTER JAM – cutter knife has failed to move	NO	YES <S92>
41H	65	GOOD STATUS – printer is ready	NO	YES <S92>

Normal Status printer will go offline in error state.

While the printer asynchronously sends status messages whenever a change in status occurs, status commands can only be processed when the printer is ready and fully operational (paper loaded, no faults, etc.). In other words, **no status responses will be sent while the printer is busy and/or in an error state.**

Printer will send the below unsolicited and solicited status messages:

Hex	Dec	Description	Unsolicited	Solicited
06H	6	TICKET ACK – Sent after each receipt or ticket is printed	YES	NO
0FH	15	LOW PAPER – used with optional low paper sensor	YES	NO
10H	16	OUT OF PAPER – printer runs out of media	YES	NO
11H	17	X-ON – sent when printer goes ready	YES	YES <S1>
12H	18	POWER ON – sent when printer is powered on	YES	NO
13H	19	X-OFF – sent when printer goes busy	YES	NO
18H	24	PAPER JAM – printer is in a media jam error state	YES	NO
19H	25	ILLEGAL DATA – when printer receives illegal data	YES	NO
1AH	26	POWERUP PROBLEM – printer has powerup error	YES	NO
1CH	28	DOWNLOAD ERROR – error downloading font or image	YES	NO
1DH	29	CUTTER JAM – cutter knife has failed to move	YES	NO

Single Ticket Status Mode <s90><p> printer will remain online during error state. Printer will issue a black receipt upon receipt of said command. This command only needs to be sent once to take effect.

The printer will respond to all status requests received during an error state. Disables various unsolicited status messages, see table below. However, non-status related data should **not** be sent during an error state, as it may cause unpredictable results. This mode should only be used when data is sent for one receipt or ticket at a time. After sending each receipt or ticket, the user should send an <S92> status request and receive either a “good status” (41H) or *low paper* (0FH) prior to sending additional receipt or ticket data.

Printer will send the below unsolicited and solicited status messages:

Hex	Dec	Description	Unsolicited	Solicited
06H	6	TICKET ACK – Sent after each receipt or ticket is printed	YES	NO
0FH	15	LOW PAPER – used with optional low paper sensor	YES	YES <S92>
10H	16	OUT OF PAPER – printer runs out of media	NO	YES <S92>
11H	17	X-ON – sent when printer buffer is ready after being full	YES	NO
12H	18	POWER ON – sent when printer is powered on	YES	NO
13H	19	X-OFF – sent when printer buffer is full	YES	NO
18H	24	PAPER JAM – printer is in a media jam error state	NO	YES <S92>
19H	25	ILLEGAL DATA – when printer receives illegal data	NO	YES <S92>
1AH	26	POWERUP PROBLEM – printer has powerup error	NO	YES <S92>
1CH	28	DOWNLOAD ERROR – error downloading font or image	NO	YES <S92>
1DH	29	CUTTER JAM – cutter knife has failed to move	NO	YES <S92>
41H	65	GOOD STATUS – printer is ready	NO	YES <S92>

Click here to return to > [Table of Contents](#)

APPENDIX F – BLUETOOTH CONNECTION

If your printer is equipped with an optional Bluetooth interface port, then you will see the following in the Interface 2 or Interface 3 field of the serial number tag.

- **BT LE** - Printer is configured for Bluetooth Classic Mode.
- **BT+** - Printer is configured for Bluetooth Classic Mode.
- **BLE+** - Printer is configured for Low Energy Mode.

BLUETOOTH CLASSIC

If the printer has optional Bluetooth interface and it is enabled, then you should see BLUETOOTH = ENABLED on the self-test printout that is issued when the printer's center TEST button is pressed.

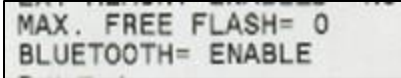

Android Connection

The below provides an overview of an Android connecting to a BOCA printer with optional Bluetooth interface.

1. Swipe down from the top of the screen.

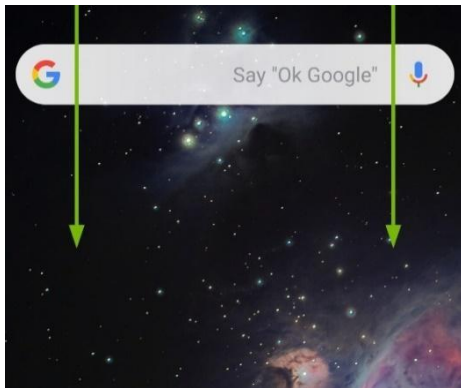

2. Press and hold the Bluetooth icon to access the Bluetooth screen.

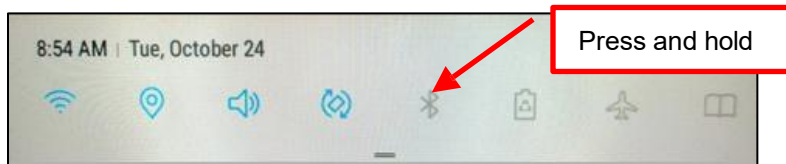

3. If Bluetooth is OFF, then turn ON.

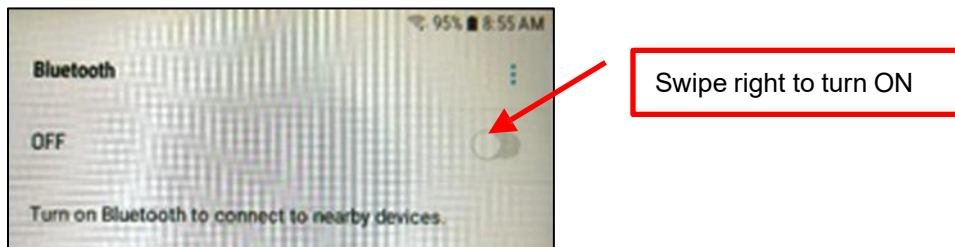

- Once turned ON, a list of Bluetooth devices will be shown. Under AVAILABLE DEVICES you should see the serial number of the printer you are trying to pair to (Boca#####) For example if your printer was serial number 523706 then you would see Boca523706.

Tap on the BOCA printer you want to pair.

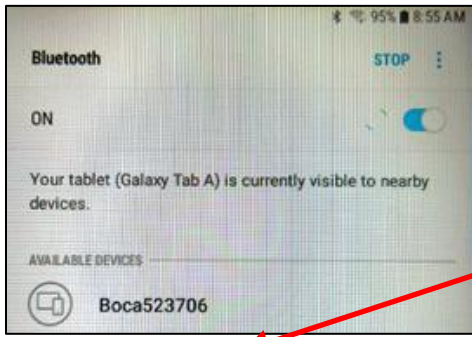

Tap on printer you want to pair.

- You will see the below during the pairing process.



- You will see the below once the printer has been paired to the device.

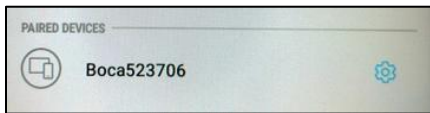

iPad Connection

The below provides an overview of an iPad connecting to a BOCA printer with optional Bluetooth interface.

- Touch the setting icon. 
- When setting menu comes up click on Bluetooth.
- Turn Bluetooth ON if it is OFF.



- Under DEVICES you should see the serial number of the printer you are trying to pair to (Boca#####) For example if your printer was serial number 000000 then you would see Boca000000

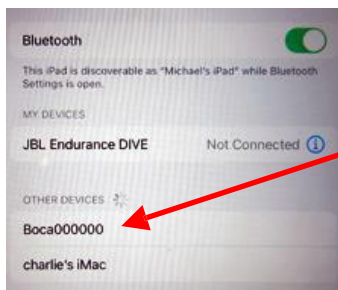

Tap on printer you want to pair.

5. Touch on this serial number to enable the iPad to pair to it.
6. The iPad should show that it is connected when successfully paired.
7. When the printer is powered off the iPad will disconnect from the printer. When the printer is powered on you will need to manually reconnect to the printer.

You may use our iPad test program that is on the Apple store to test the printer. The search will need to be done via the iPad and search name would be *BocaPrinter* (<https://itunes.apple.com/us/developer/boca-systems/id951179235>).

Windows 11 Connection

The below provides an overview of a Windows 11 connecting to a BOCA printer with optional Bluetooth interface.

1. In your Windows Bluetooth device settings, set Bluetooth devices discovery setting from Default to Advanced. The below link reviews how to set Bluetooth to advanced settings.

<https://help.cricut.com/hc/en-us/articles/16511514972183-Windows-11-Bluetooth-Devices-Discovery-Issues#:~:text=Open%20open%20Bluetooth%20settings%20and,setting%20from%20Default%20to%20Advanced>

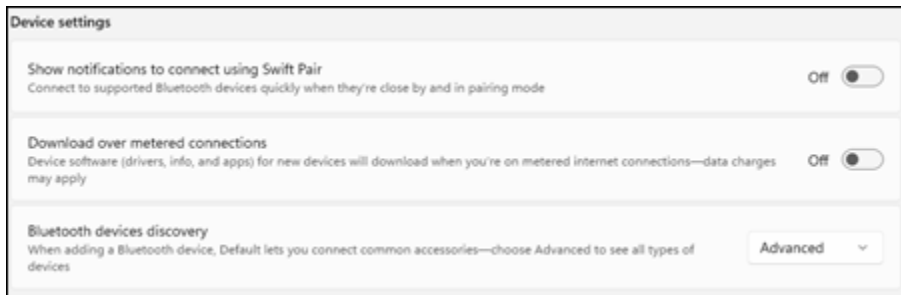

2. When you do your search, you should now see Boca#####. In the below example my test printer is serial number123456, you should see Boca522557. Click on it to pair your PC with the printer and follow the instructions provided.

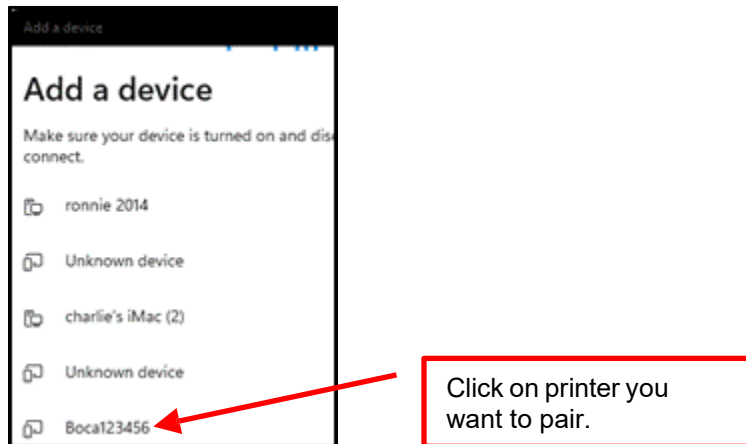

3. Once connected go to Device Manager settings, the blow link shows various ways to open Device Manager.

<https://help.cricut.com/hc/en-us/articles/16511514972183-Windows-11-Bluetooth-Devices-Discovery-Issues#:~:text=Open%20open%20Bluetooth%20settings%20and,setting%20from%20Default%20to%20Advanced>

- Once open, look under Ports (COM & LPT) and you should see Standard Serial over Bluetooth link (COM#). In the below example W11 provided two COM ports, which the lowest number COM port should be used. This this case I would use COM5. Your COM port values may be different.

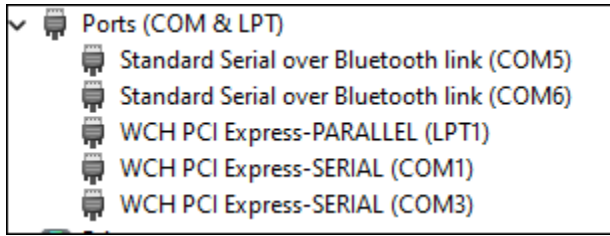

- Your software application would then use this COM port connection to communicate to the printer through.

The Bluetooth will need to be disabled if you choose to communicate to the printer via the ETHERNET or USB port.

The command below may be sent. This command only needs to be sent to the printer once to take permanent effect and the printer will reset upon receipt of said command. The [Appendix E DOWNLOADING SOFTWARE COMMANDS](#) section provides download procedures.

<bld> = DISABLE

<ble> = ENABLED

Click here to return to > [Table of Contents](#)

APPENDIX G – CONFIGURE WI-FI CONNECTION

To use the wireless capabilities of a printer equipped with the optional wireless interface (Wi-Fi), it will first be necessary to set up the printer with information and security settings that match the settings of the compatible wireless server/router you are connecting to. Printer purchased after April 2014 can support IEEE 802.11g compatible wireless server/router. Printers purchased after July 2020 can support 802.11 b/g/n wireless networks. *The RJ12 serial port will not work with a printer that has optional Wi-Fi interface.*

Our Wi-Fi printer is designed to work with a wireless router.



We recommend that the Wi-Fi be configured by either your system administrator or IT support staff who is knowledgeable about your network and Wi-Fi configurations.

You need to confirm / know the following:

- Wi-Fi router is a b/g/n wireless device that supports 2.4 GHz speed (we do not support 5 GHz speed)?
- If the printer needs to be configured for DHCP or Static IP address?
- SSID name of the router you are connecting to?
- What security mode is required (Disabled, WAP, WAP2 or WEP)?
- If security mode is required, then need to know said Pass Phrase/Shared Key (WAP or WAP2) or WEP Encryption/ Key value?

You must use our Configure and Test program for Windows or Customer program for MAC (see [Appendix F](#)) and be connected to the printer via a wired connection.

- If connection via Ethernet, use the IP address that is on the self-test ticket.
- If connecting via USB then the appropriate print driver needs to be used:
 - **MAC** – https://bocasystems.com/documents/MAC_Driver_Install_Guide_2021.pdf
 - **WINDOWS** - <http://www.bocasystems.com/documents/WindowsDriverInstallGuide.pdf>

The following will guide you with configuring your printer if it has optional Wi-Fi interface port.

1. For initial installation the printer must be as close as possible to the Wi-Fi router itself. This will ensure maximum signal strength. Once you have confirmed the Wi-Fi is operational, the printer may be moved to its desired location.
2. You need to confirm you can print a ticket using our Configure and Test program for Windows or Customer program for MAC (see [Appendix E](#) for Windows and [Appendix F](#) for MAC). The printing of a ticket via this program will confirm it is communicating with the printer. Leave the program open and move onto the next step.
3. In the Configure and Test program for Windows click on the “Setup Wi-Fi button. In the Customer program for MAC select “Setup Wi-Fi” under the “Select Printer Operation”.

4. When the Configure Printer Wi-Fi and Security menu comes up you have a few choices.
 - a. **Wireless Mode** – Infrastructure (this is default setting). **DO NOT SELECT Ad Hoc (peer to peer)**
 - b. **Disable Wireless** – You would choose this if you wanted to disable the Wi-Fi
Enable with Static IP – This would be for networks that require a static IP address.
Enable with DHCP IP - Automatically attempts to get an IP address from Local Server (this is the most common one and the one we will be using for the rest of the steps).

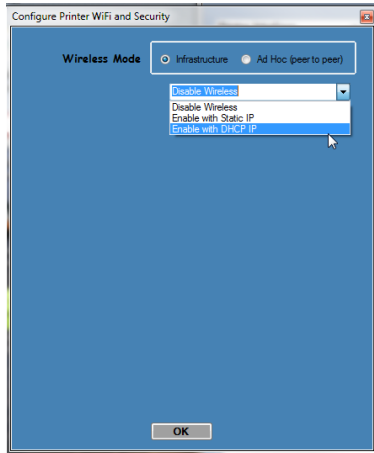

5. You will need to enter the **SSID value**. The Service Set Identifier is a 1 to 32 byte string. This normally would be the name of the Wi-Fi router you are connected to. **Please note the ID is case sensitive.**

SSID:

6. Security Mode: you will need to choose the security mode that is appropriate for your Wi-Fi router.
 - Disable** – Allows the user to communicate through the wireless network without any security encryption involved.
 - WPA** – Go to [Step 7](#)
 - WPA2** – Go to [Step 7](#)
 - WEP** – Go to [Step 8](#)

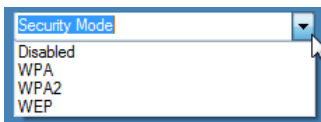

7. **WPA and WPA2 Personal Security Mode** – Allows the user to communicate through the network using WPA or WPA2 Personal wireless encryption. When this security encryption mode is chosen it will be required to enter the “WPA Shared Key” for the local wireless network. Some networks also enforce the use of an optional key value. The optional prompt field is provided for those networks. **Please note the key is case sensitive.** Finally click on OK to have these values transmitted to the printer (through the cable). The printer will reset and upon re-initialization it will establish wireless communication with the local network. The handshaking involved in establishing wireless communication can take up to 30 seconds. Go to [step #9](#).

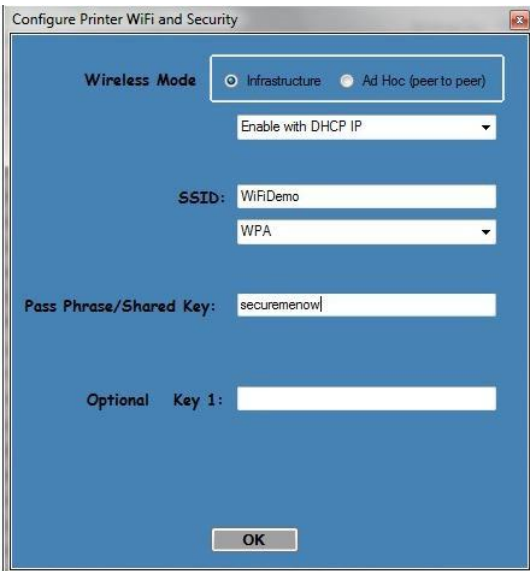

8. **WEP Security Mode** – Allows the user to communicate through the network using WEP wireless encryption. With WEP one can select 64 bit or 128-bit encryption. When the security encryption mode is chosen it will be required to enter the “Key” for the local wireless network. **Please note the key is case sensitive.** Some networks also enforce the use of a default transmit key. If needed select one, else leave it set to “1”. Next the four security key values will have to be entered to match those of the local network. Finally click on **OK** to have these values transmitted to the printer (through the cable). The printer will reset and upon re-initialization it will establish wireless communication with the local network. The handshaking involved in establishing wireless communication can take up to 30 seconds. Go to [step #9](#).

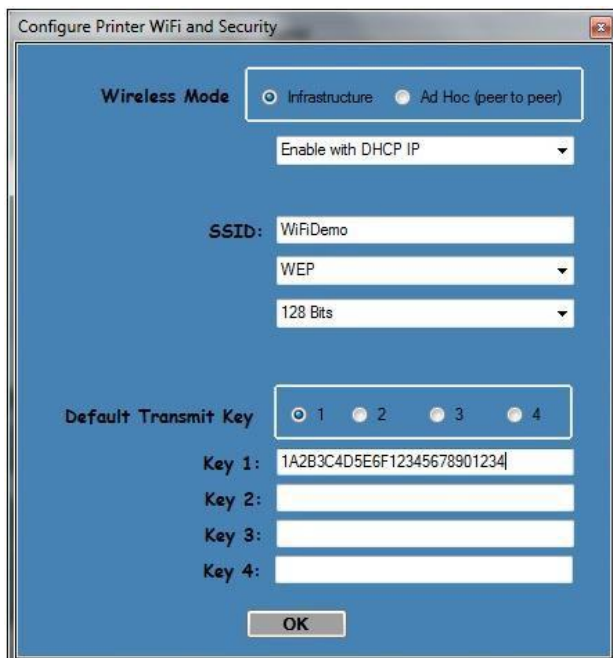

9. The printer will reset. Depending on your operating system, this rest may happen in less than 60 seconds or as long as 5 minutes. Upon re-initialization it will establish wireless communication with the local network. Depending on your network, a connection can be established in less than 60 seconds or as long as 5 minutes. At this point the printer is connected to your Wi-Fi router.

10. Press the TEST button to print out a self-test ticket. This ticket will show the IP address that was acquired by the printer. You may use the configuration and test program to test this interface connection. You would run the program like you are connecting to an Ethernet printer and enter in the IP address that is shown on the self-test ticket.

If it fails or displays IDLE then there is a problem. See [item #14](#) on the Troubleshooting Guide.

Please go to the link below if you need assistance in configuring your Wi-Fi connection.

www.bocasystems.com/onlinesupportform.html

If your printer has an options Ethernet port then this port will be disable while the printer is in Wi-Fi mode. The printer is not able to run both Ethernet and Wi-Fi at the same time. If you need to go back to using the Ethernet port then the Wi-Fi needs to be disable. This may be done by repeating the above procedure but at step # 4 choosing **Disable Wireless**.

Click here to return to > [Table of Contents](#)

APPENDIX H – SERVICE PLANS

For enhanced [warranty](#) coverage or for an out of warranty printer, we offer two types of service plans.

GOLD SERVICE

- Printer repair at BOCA facility (3 business day turnaround)
- Replace defective parts (ship within one business day) – customer must return defective parts
- Return shipping (from factory to customer) via UPS Ground service (other delivery options to be billed to the customer)

PLATINUM SERVICE

- Printer repair at BOCA facility (3 business day turnaround)
- Replace defective parts (ship within one business day) – customer must return defective parts
- Return shipping (from factory to customer) via UPS Ground service (other delivery options to be billed to the customer)
- Replacement printer is provided within one business day, if requested. (This service will become available one week after the platinum plan begins.)

The following items are not covered by the service plans:

- **Preventative Maintenance** – the customer is responsible to provide a reasonable level of preventative maintenance as described in [section 9](#) of this manual.
- **Negligence** – parts damaged by misuse or negligence, including damage due to defective ticket stock, is not covered
- **Pre-existing conditions** - all printers must be in good working order prior to entering into the plan. The customer will be invoiced for any parts and repair work needed on printers which were defective prior to the start of the maintenance plan. BOCA reserves the right to make this determination unilaterally.
- **Incoming Shipments** – the customer is responsible for shipping charges to BOCA.

Please visit the link below for the latest pricing on our service plans.

www.bocasystems.com/serviceplans.html

APPENDIX I – TECHNICAL SUPPORT

Please go to the link below if you require technical support with your BOCA printer. There is no fee for initial email support.

www.bocasystems.com/onlinesupportform.html

PHONE / EMAIL SUPPORT - BOCA provides free technical support via email for all printers under warranty or service contracts. (Phone support may be provided for covered printers at BOCA's sole discretion as needed.) Email support for non-warranty/non-contract printers is billable at \$100.00 per incident. However, BOCA may (at its sole discretion) choose to waive this fee for customers in good standing. Phone support for non-warranty/non-contract printers will be billed at a rate of \$100.00/hour for Level 1 support and \$200.00/hour for Level 2 support. Billing time will be rounded up to the nearest hour. A valid credit card number is required for phone support payments.

Click here to return to > [Table of Contents](#)